

# SENSE

## Washbasin tap, contactless



Product code: BQR\_N29V

EAN: 5907650819752

Color: nero

Warranty [years]: 7

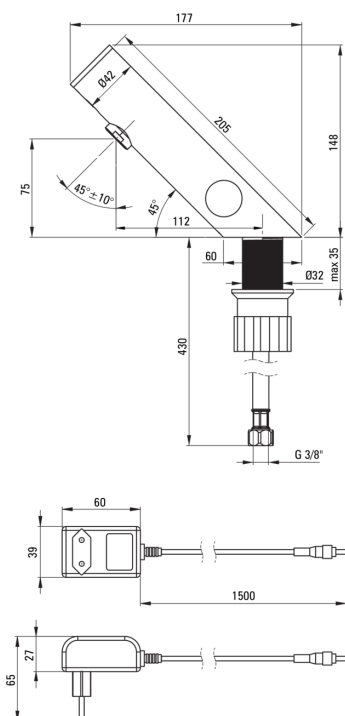

### Mixer

Finish	nero
Material	steel 304
Mixer type	sensor
Installation method	standing
Flow class [l/min]	Z - 4-9 l/min
Acoustic group [db]	I (x ≤ 20)
Check valves	Yes

### Spout

Mixer spout range [mm]	110
------------------------	-----

### Aerator

Aerator type	silicone, swivel
Aerator size	M24

### Connecting hose

Length [mm]	450
Installation thread	1/2"
Connection thread	M8

### Features:

- 45 cm connection hoses included
- Contactless tap with a motion sensor
- Innovative, durable and easy to clean Nero coating
- The mounting sleeve facilitates the installation of the mixer
- Silicone aerator for easy limescale removal
- The movable aerator allows you to direct the water stream
- Only the best materials, the quality of which has been confirmed by laboratory tests
- Anti-vandal tap - resistant to damage
- The mixer is manufactured in Poland, with the utmost care for product quality.
- Z flow class (4-9 l/min) allowing for water consumption reduction
- The mixer is equipped with a stream aerator
- Sensor Duopulse - a sensor that draws current impulsively
- The sensor is located on the top of the body, free from dirt and accidental signals
- Power supply type IP 54, resistant to water splashes and dust. Galvanic isolation separates the dangerous voltage circuit from the sensor circuit, ensuring maximum safety.
- The mixer is equipped with non-return valves so that the mixed water does not flow back into the installation
- The offer includes a cleaning agent for fixtures in all colors